



GDHA INTWM7KG
Built-In Washing Machine
User Manual

Contents

Safety Warnings	3
Unpacking	6
Installing Your Washing Machine	7
Moving and Installing	8
Product Overview	13
Preparation	15
Before First Use	17
Wash Setting	17
Important Information	19
Maintenance – Cleaning the Washing Machine	21
Specifications	23
Product Fiche	24

Safety Warnings

For your continued safety and to reduce the risk of injury or electric shock, please follow all the safety precautions listed below.

WARNING!

- If you will not be using the washing machine for a while such as when you go on holiday, disconnect the plug from the mains supply and turn off the water supply to the washing machine. This is particularly important if there is no drainage around the washing machine.
- If the water supply is left on, water pressure may build up and cause a leak.

General Use

- Transit bolts are used to transport the washing machine. You should remove these using a spanner or similar tool before you install the washing machine. If you do not, it will cause strong vibrations when the washing machine is spinning.
- Do not install your washing machine anywhere that is damp or exposed to the weather. If you do, it may cause an electric shock, fire, failure or deterioration.
- Do not pour water directly onto any part of the washing machine. It may cause a short circuit or electric shock.
- Keep burning objects such as candles or cigarettes, away from the washing machine. They may cause a fire or damage.
- Keep flammable substances well away from the washing machine – for example kerosene, gasoline, benzene, paint thinner and alcohol, or clothing soaked with these. They may cause an explosion or a fire.
- This washing machine is only suitable for washing textiles labelled 'washing machine washable'.
- Do not connect the washing machine to hot water. The washing machine works with cold water only.
- Before you start using the washing machine, turn the tap on to check that the hose is properly connected. If it's not, there may be a water leak.
- Do not put too much laundry or detergent into the washing machine. It may cause issues with the washing machine or laundry.
- Be careful not to get your laundry caught in the door when you close it. This could cause a water leak or damage your laundry.
- This washing machine is for household (domestic) use only.

Power Source and Cable

- Use an independent household dedicated mains socket, rated at 10 Amp 220V to 240V AC. If the washing machine is plugged in with other appliances, it may overheat and cause a fire.
- Make sure the mains plug is pushed firmly into the socket. A loose connection may overheat and cause electrical shock or a fire.
- Check the mains lead and mains plug for any damage. If the mains cable is damaged, it must be replaced by the manufacturer, its service agent or similarly qualified persons in order to avoid a hazard.
- Unplug the mains lead when cleaning the washing machine.
- Do not touch the mains lead or mains plug with wet hands. It may cause an electric shock.
- Check the mains plug regularly for dirt. If dirt accumulates on the mains plug, it could cause a fire. To prevent this, unplug the cable and clean the mains plug with a dry rag.
- If you disconnect the mains plug, hold onto the mains plug not the cable. Pulling the cable may cause an electric shock or a fire.
- Do not use a mains plug adapter or extension cable. It may overheat and cause a fire.
- Make sure your home voltage matches the voltage displayed on the washing machine. If you are not sure, contact an electrician.
- The mains plug must remain accessible to allow disconnection of the appliance after installation, or an all pole switch must be incorporated in the fixed wiring in accordance with the wiring regulations.

To Prevent Injury / Damage

- Do not climb on the washing machine. You may hurt yourself or damage the washing machine.
- When opening and closing the door ensure you keep fingers away from the door hinge, or this could lead to injury.
- Check your washing for objects such as nails, pins, coins, clips etc. They could damage your laundry or the washing machine.
- To prevent any large, heavy objects (e.g., buckles, large buttons, etc.) from hitting the glass door, turn your clothing inside out or remove the heavy objects. They could damage your laundry or the washing machine.
- Do not wash, rinse or spin water-proof sheets or clothing. These may cause vibration or washing machine failure during spin-drying, which could lead to injury, damage to the washing machine or damage due to water leaking.

- Be careful when draining hot water or any detergent from the drum.
- Do not dismantle, repair or modify the washing machine. The washing machine could malfunction and cause a fire or injury.
- This appliance can be used by children aged from 8 years and above and persons with reduced physical, sensory or mental capabilities or lack of experience and knowledge if they have been given supervision or instruction concerning use of the appliance in a safe way and understand the hazards involved. Children shall not play with the appliance. Cleaning and user maintenance shall not be made by children without supervision.
- Children should be supervised to ensure that they do not play with the appliance.
- Children of less than 3 years should be kept away unless continuously supervised.
- Do not touch the laundry inside the washing machine, until the drum has completely stopped. Even if the drum is spinning at low speed it can cause an injury. Take particular care of children in this respect.
- The appliance is to be connected to the water mains using the new hose-set supplied. Old hose-sets should not be reused.
- The ventilation openings in the base of the washing machine must not be obstructed by a carpet.

Unpacking

Remove all items from the packaging. Retain the packaging. If you dispose of it please do so according to local regulations.

The following items are included:

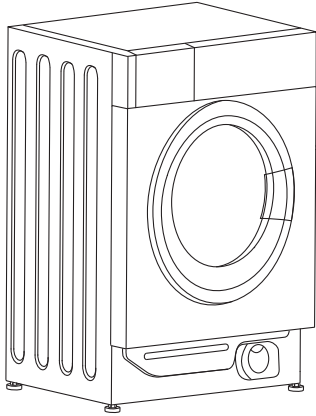

The Main Unit

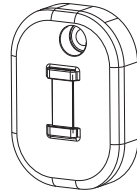

Magnet x 2

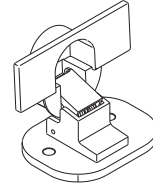

Hinge x 2



Screw A x 8



Screw B x 6

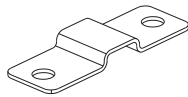

Spacer x 2

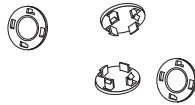

Transport Bolt Cover x 4

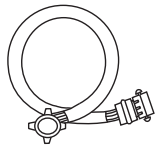

Water Supply Hose



Door Drill Template

■ Installing Your Washing Machine

Choosing the Right Location for Your Washing Machine

- Make sure there's enough space for your washing machine.
- Install your washing machine on a flat, stable surface to avoid excessive vibrations and noise.
- Don't install your washing machine in direct sunlight or in a place where temperatures can reach freezing.

Removing the Transit Bolts

Four transit bolts keep the interior of the washing machine in place while it's being moved. They need to be removed before installation. Use a spanner (not supplied) and follow the instructions detailed below.

To remove the transit bolts:

1. Use a spanner to loosen the four bolts. They are located at the rear of the washing machine.
2. Pull the bolts out horizontally. Make sure the entire bolt is removed.
3. Push the four cover caps (included with your accessories) into the respective bolt holes.

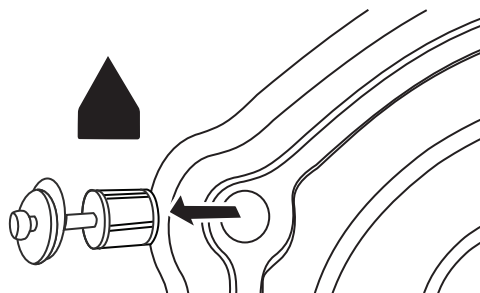

Moving the Washing Machine from One Location to Another

Before you move the washing machine:

- Shut off the tap and run the washing machine to drain the water. Drain any remaining water from the pump hose.
- Disconnect the mains cable.
- Attach the transit bolts.

● Moving and Installing

Hose and Cable Lengths

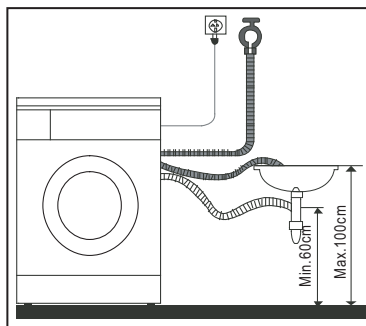
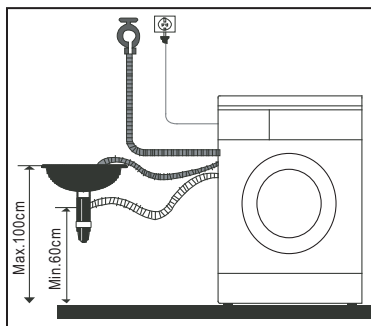

Levelling the Washing Machine

There are levelling feet on the underside. They must be adjusted to make sure the washing machine is level.

1. On each foot, loosen the lock ring by turning it clockwise.
2. Adjust all feet by rotating each upwards or downwards.
3. Use a spirit level to ensure the washing machine is level.
4. Tighten each lock ring by turning them anti-clockwise (towards the washing machine body).

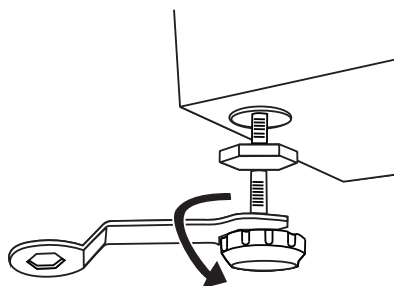

Ensure all lock rings are tightened securely. Check that the feet are still bolted to the washing machine - if they're unbolted, the washing machine will move around.

Water Supply Hose

Points to remember

- Follow the instructions in this section to avoid water leaks.
- Don't connect the hose to a combination tap.
- Don't twist, squash, modify or cut the hose.
- This machine is designed to connect to the cold water supply. Do **not** connect to the hot water supply.
- Use only the new water supply hose supplied. Old hose sets should not be reused.

Connecting the Water Supply Hose

1. To prevent leakage from the connection joints, ensure the rubber washer seals are fitted to each end of the water supply hose. Do not use without the seals in place.
2. Fit the straight end of the water supply hose to the cold water tap.
3. Connect the angled end of the white headed hose to the water inlet valve on the machine. Hand tighten the plastic parts of the connections. If you are unsure, please call a qualified plumber for safer connections.
4. Open the tap slowly and check that there are no leaks around the connection joints.

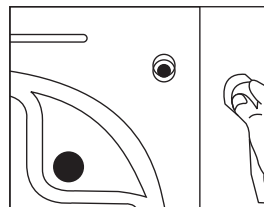
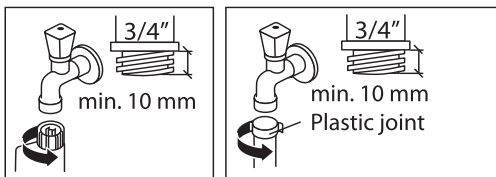

Water Drain Hose

Points to remember:

- Don't twist, pull out or bend the drain hose.
- Your washing machine should be no more than 85cm from the drain outlet.
- The water drain hose should be mounted at a height of minimum 60 cm, maximum 100 cm from the ground.

Installing into Kitchen Furniture

This appliance is designed to be built into kitchen furniture. Follow the measurement below for correct installation.

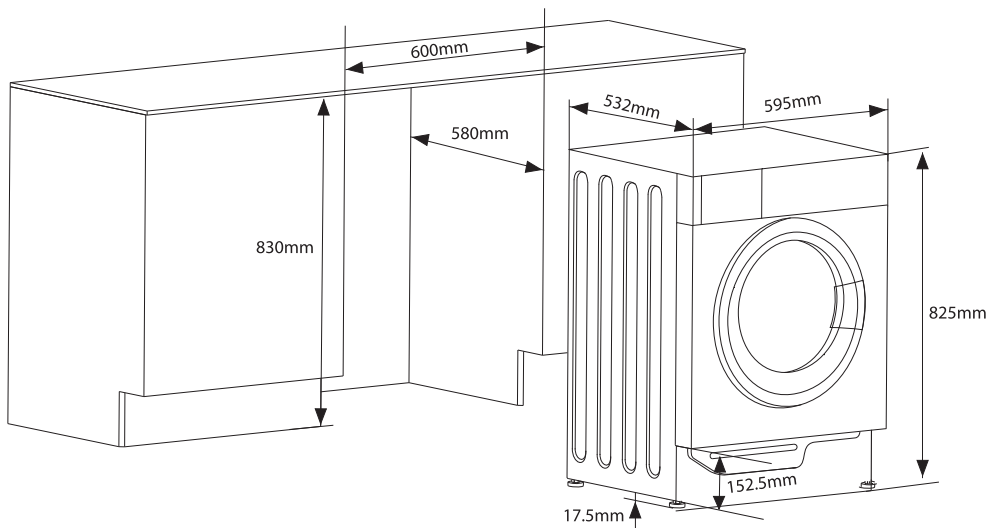

This appliance is also designed for the assembled cabinet door (16-22 mm thick) to open from the left or right.

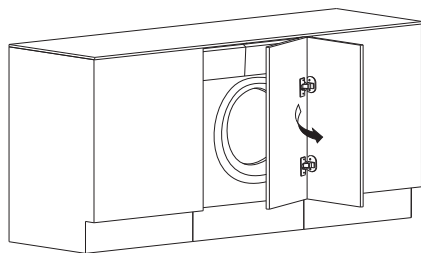

Door open from left to right

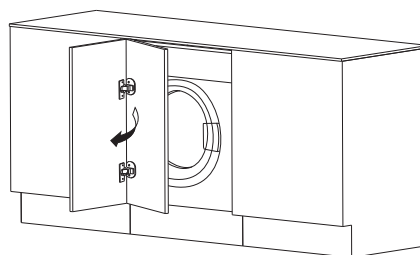

Door open from right to left

1. Mark on the cabinet door the measurement and dimension of the cupboard and washing machine.

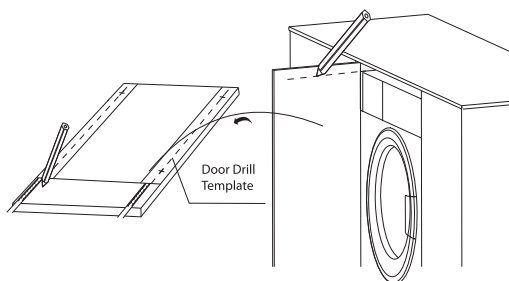

- Decide from which direction the cabinet door will open.

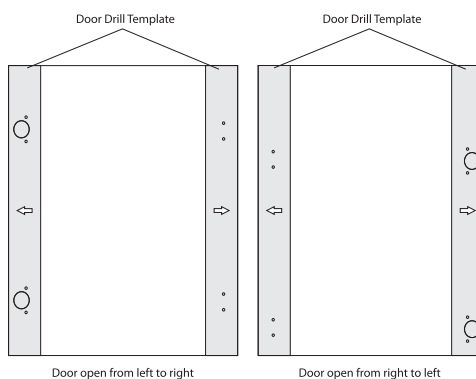

- Depending on the direction the cabinet door will open and close, drill holes (hinge \varnothing 35 mm; screw \varnothing 2 mm) on the cabinet door according to the markings and measurements on the Door Drill Template.

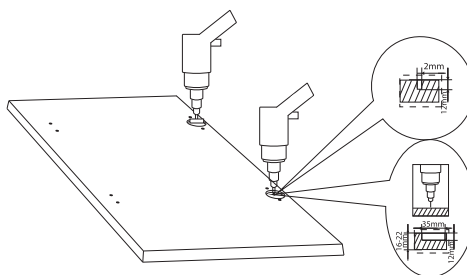

- Screw the hinges on the cabinet door using screw A.
- Screw the spacers on the cabinet door using screw A.

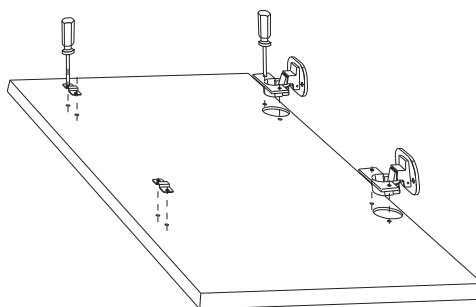

- Depending on the direction the cabinet door will close, screw the magnets on the machine using screw B.

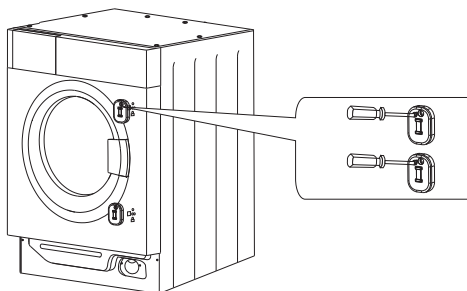

7. Fix the cabinet door on the machine.
Screw the hinges on the machine using screw B.
8. Close the cabinet door. Spacers on the cabinet door shall attract to the magnets on the machine.

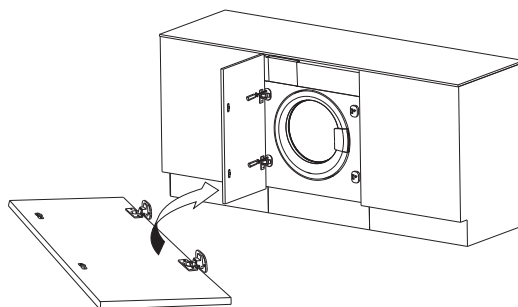

Connecting to the Mains Supply

For your safety:

- Do not use a mains plug adapter or extension cable.
- If the mains cable or mains plug are damaged, stop using them and call a qualified technician for assistance.
- An earthed plug has been attached to the power cable of your washing machine. This plug must be inserted into an earthed socket capable of supplying 13 Amps. If you have no such sockets and fuses in your house, call a qualified electrician.
- The mains plug must remain accessible to allow disconnection or an all pole switch must be incorporated in the fixed wiring in accordance with the wiring rules.

Installation Check List

By now, you should have installed the washing machine.

Let's go through the checklist to ensure that the installation has been done correctly!

Questions		Checkbox
Transit bolts - Have you removed them and attached the cover caps properly?		
Levelling feet	Adjustable Feet - Are they bolted securely to the washing machine?	
	Feet Cushions - Are they standing flat?	
Power supply - Is the household dedicated mains socket rated for 220V - 240V AC and can supply 13 Amps?		
Location - Is your washing machine on a flat, stable surface?		
Water Supply Hose - Is it free from leaks and is the water supply normal?		

Product Overview

The unit

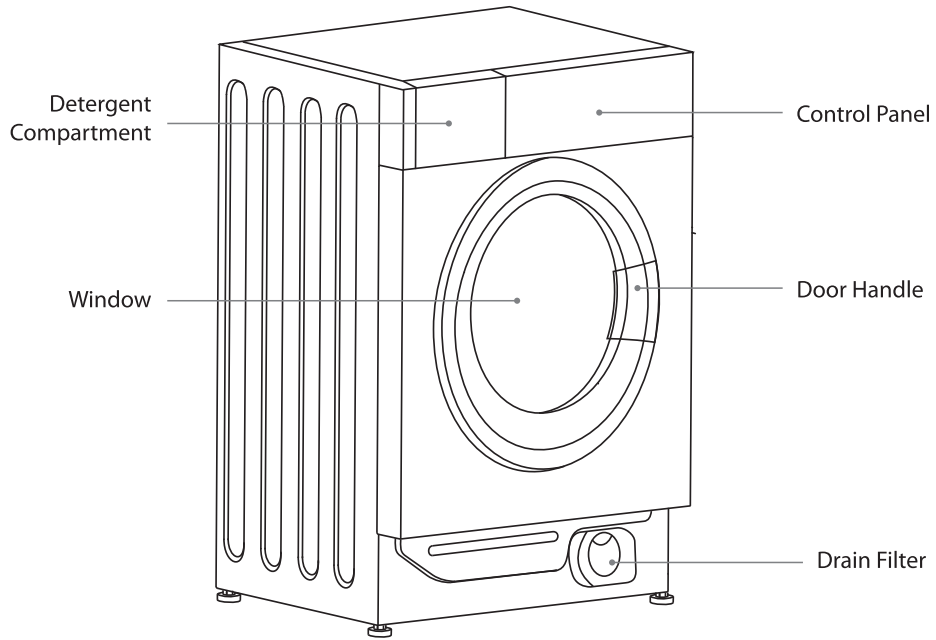

The Control Panel

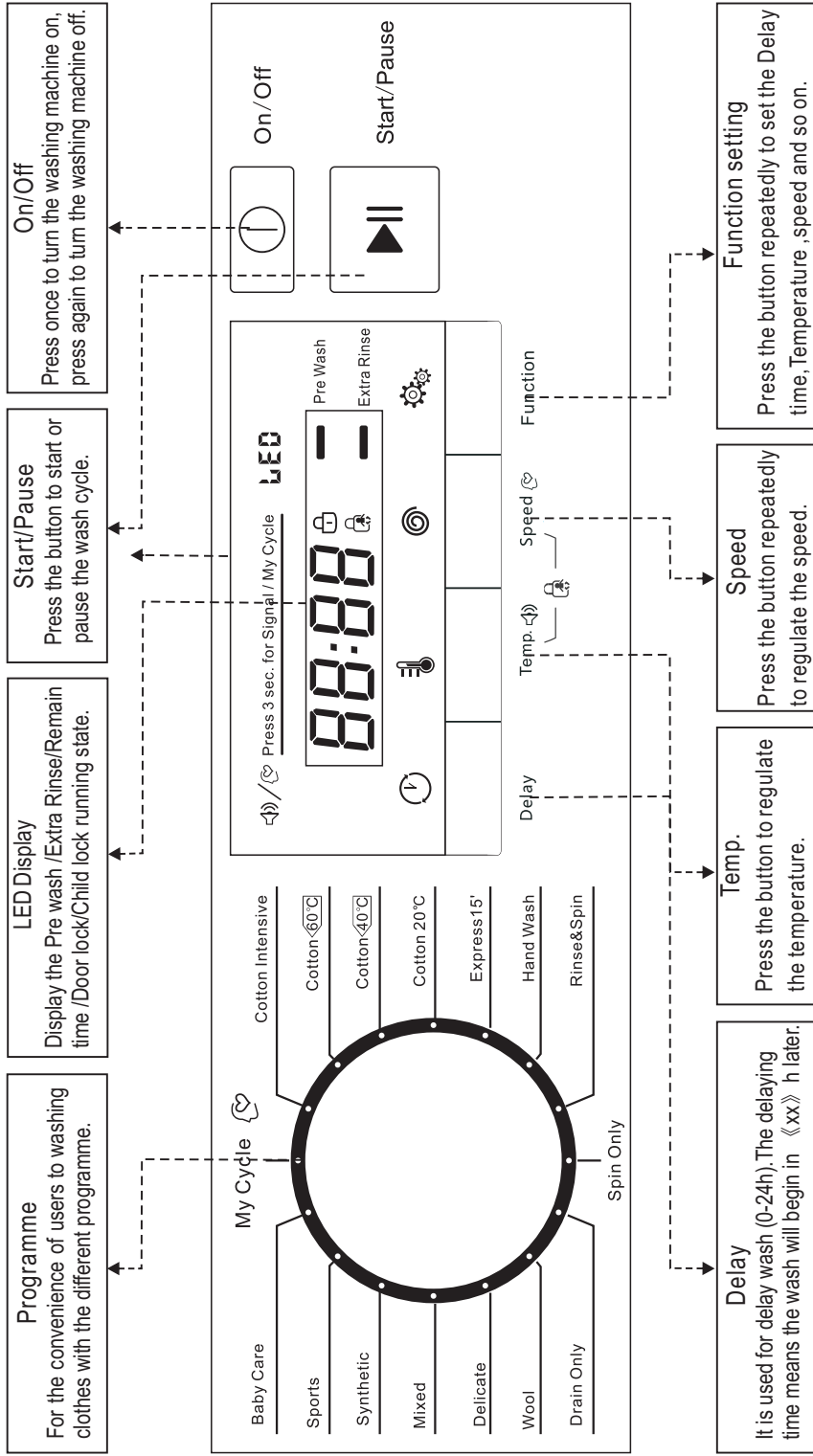

Notes:

1. The Control panel line chart is for reference only, Please refer to real product as standard.
2. The Control panel could be changed without written notice. Please visit the website of Washing Machine or call up the service line for consultation.
3. When the lights of Speed (400, 600, 800, 1000, 1200, 1400) are off means the speed is 0.

Preparation

Read the following to understand how best to prepare your laundry for washing.

Organising Laundry

- Read the washing label on each garment to help you sort your washing into different loads.
- Sort the laundry by colour, type of fabric and by how soiled it is. This will help you choose the correct programme and temperature for each wash.
- Do not exceed the maximum load! See the table for the maximum load of the type of fabric to wash.

Fabric Type	Maximum Loading Capacity (kg)
Cotton	7.0
Synthetics	3.5
Wool	2.0
Delicates	2.5

Preparing Laundry

- Treat stains before washing.
- Some items should be put into a cleaning net before going into the washing machine. i.e. bras with metal wires, tights and lace clothing to prevent damage.
- Check that pockets do not contain any objects which may damage your clothes and the washing machine.
- Tie up any loose strings on laundry, close zippers and reverse clothing with zips inside out.
- To prevent any large, heavy objects (e.g., buckles, large buttons, etc.) from hitting the glass door, turn your clothing inside out, or remove the heavy objects. These could damage your laundry or the washing machine.
- Remove any surplus hair, animal fur, sand, and other materials with a brush before washing.
- If clothes have raised fabric, turn them inside out.
- Clothes that are not colour fast should be washed separately.
- Insert your clothes into the washing machine. Close the washing machine door. Ensure that you do not trap any items of clothing between the loading door and the rubber seal.

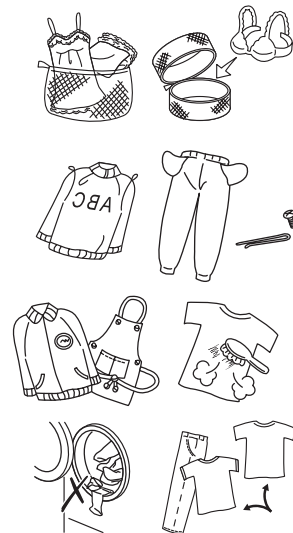

Adding Detergent and Softener

- Add detergent into the appropriate dispenser.
- Apply softener before you start washing.
- Apply detergent and softener according to the washing amount, the soiling level, the water hardness in your area and the manufacturer's instructions of these products.
- For slightly dirty clothes, put a small amount of detergent into compartment II of the detergent drawer.
- For excessively dirty clothes, put $\frac{1}{4}$ of the detergent to be used into compartment I of the detergent drawer and the remaining amount into compartment II.
- Do not use the washing machine when the detergent drawer is removed. It may cause a water leak or it may not work normally.
- If you forget to add detergent, you can drain the washing machine by running a drain only programme. Then you can add detergent and start the programme again. Detergent only reaches the drum when water flushes through the detergent drawer.
- To prevent powder detergent from staying in the drawer, dry the inside of the drawer with a cloth. Make sure the powder isn't lumpy when you add it into the drawer.
- If the rinse cycle isn't removing all the detergent from your wash, use less detergent.
- Softener should not exceed the MAX level in the compartment.
- Wash out unused softener with a splash of water or a damp cloth after the programme has finished.
- You can use liquid detergent in all programmes. For this, pour the required amount of liquid detergent into compartment II of the detergent drawer.

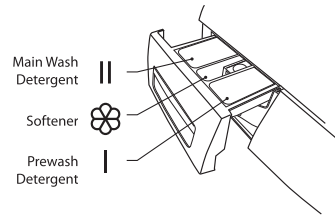

Before First Use

Before washing your clothes for the first time, run a full wash programme first:

1. Connect the machine to the mains power supply and the water supply.
2. Put a small amount of detergent in the detergent drawer. Close the drawer.
3. Press the **Power** button.
4. Select a wash programme.
5. Press the **Start / Pause** button.

Wash Setting

Standard Washing

1. Pull the door handle and put the laundry in the drum. (Refer to Preparation to sort your laundry before it goes into the drum.) Make sure no washing gets caught in the door. Close the door.
2. Press the **Power** button and turn the **Programme Dial** to select your wash programme.
3. Select other functions if desired.
4. Add detergent into the detergent drawer. The quantity of detergent will depend on the amount of laundry, the degree of soiling and the water hardness. Use the amount of detergent suggested on the packaging.
5. Press the **Start / Pause** button to start the washing.
6. The washing machine will sound when the wash programme is completed.

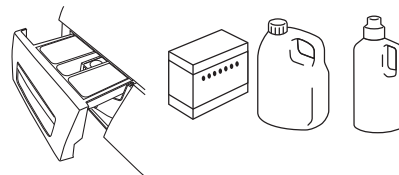
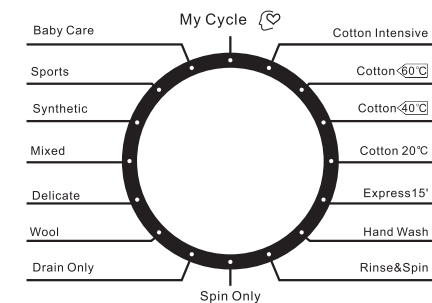

Removing Washing (Once programme is finished)

- Door remains locked for 1 minute after wash stopped.
- Open the washing machine door and remove your washing.
- Remove any foreign objects to avoid risk of rusting.
- Leave the door and detergent drawer open so that residual water can evaporate.

Selecting the Programme

Procedure Description	Load(kg)	Detergent Box			Delay	Extra rinse	Prewash	Default Temp. (°C)	Default Time (H)	Default Speed (RPM)
		Case I	Case II	Softener Case						
Cotton Intensive	7.0	○	●	○	○	○	40	14:00	1400	
Cotton 60°C	7.0	×	●	○	○	×	60	2:40	800	
Cotton 40°C	7.0	×	●	○	○	×	40	1:47	1200	
Cotton 20°C	2.0	○	●	○	○	○	20	1:32	1200	
Express15'	2.0	×	●	○	○	×	Cold	0:15	800	
Hand Wash	2.0	○	●	○	○	○	Cold	1:00	800	
Rinse&Spin	7.0	×	×	○	○	×	-	0:31	1000	
Spin Only	7.0	×	×	×	○	×	-	0:14	1000	
Drain Only	-	×	×	×	○	×	-	0:01	-	
Wool	2.0	×	●	○	○	×	40	1:06	400	
Delicate	2.5	×	●	○	○	×	30	1:00	600	
Mixed	7.0	○	●	○	○	○	40	1:13	1000	
Synthetic	3.5	○	●	○	○	○	40	1:40	800	
Sports	3.5	○	●	○	○	○	40	1:19	800	
Baby care	3.5	○	●	○	○	○	60	1:39	1000	

The energy class is A+++ Energy test program: Cotton 60/40°C, Speed: the highest speed; Other as the default.

Half load for 7.0Kg machine:3.5Kg.

"Cotton 60/40°C" are the "standard Cotton 60/40°C" programme and the standard washing programs to which the information in the label and the fiche relates, and they are suitable to clean normally soiled cotton laundry and that they are the most efficient programmes in terms of combined energy and water consumptions for washing that type of cotton laundry, that the actual water temperature may differ from the declared cycle temperature.

● Means must ○ Means optional × Means not necessary

Notes: The parameters in this table are only for user's reference. The actual parameters maybe different with the parameters in above mentioned table.

Delay Start the Programme

1. Select a wash programme.
2. Press the **Delay** button repeatedly to set the delay hours for the programme to start (0-24 hr).
3. Press the **Start / Pause** button to confirm and commence the delay function.

To cancel the delay function:

- before the programme starts, press the **Delay** button repeatedly until 0 hr
- while the programme is running, press the **Power** button to Off.

Important Information

Washing Delicates (Wool and Silk Programmes)

These programmes rock the drum gently for best results on delicate laundry.

- Silk laundry loads: 2kg or less
- Tips for Wool programme:
Approximate Weights:
 - Wool sweater (400g)
 - Silk blouse / under garment (200g)
 - Trousers (400g)

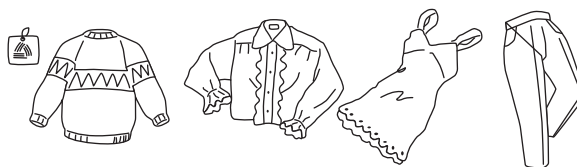

Adding Delicate Laundry Items to the Drum

- Close zips and buttons.
- Add items one by one on top of each other.
- Don't overload the drum as it may cause excessive vibrations or damage the washing machine.

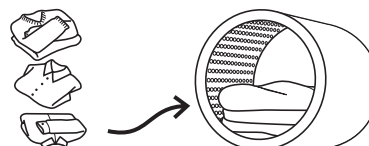

Which Detergent to Use

- For woollen items, use a mild liquid detergent. Other detergents may damage your woollen clothes.
- With Wool or Silk programmes, you may need to use an extra rinse cycle to remove excess detergent from your clothes. This depends on the amount of detergent you use, and the amount of foam that develops in the main wash cycle.

How to Set the Child Lock

The Child Lock prevents children from accidentally changing a wash programme.

1. Switch on the washing machine.
2. When the washing machine is in operation, press and hold the **Temp** and **Speed** buttons at the same time for 3 seconds to set the child lock. The Child Lock icon will light to indicate that the child lock is active.
3. If a function button of the control knob is operated while the child lock is active, the machine will beep to indicate that the child lock is in effect.
4. To deactivate child lock, press and hold the **Temp** and **Speed** buttons until the Child Lock icon LED goes out.

Muting & Turning On the Sound

- The machine will beep.
- To mute the sound, press "**TEMP**" for 3 seconds after starting the wash programme.
- To turn on the sound, press "**TEMP**" again for 3 seconds.

Maintenance - Cleaning the Washing Machine

Cleaning the Drum

Always unplug the washing machine before cleaning.

Any rust left inside the drum by metal articles must be removed immediately with chlorine-free detergent.

Never use steel wool.

Cleaning the Exterior of your Washing Machine

- Clean the outside of your washing machine with a soft cloth and mild detergent such as kitchen detergent.
- Don't splash water over the washing machine.
- Do not use cream cleansers, thinners or products containing alcohol or kerosene.

Cleaning the Detergent Drawer

1. Remove the detergent drawer by pulling and pressing gently on the rear centre part of the softener compartment.
2. Wash out old detergent from the drawer with water. (Use a cloth to clean the washing machine.) Residue detergent soon builds up if you don't clean the drawer regularly, and can develop mold.
3. Return drawer to original position.

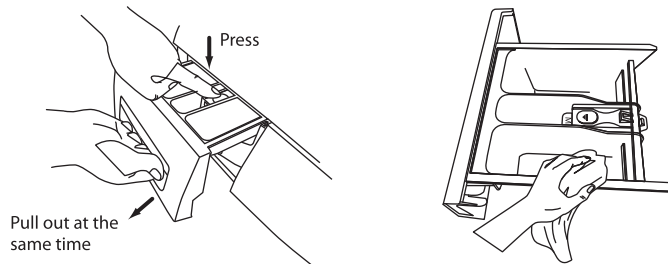

Siphon Plug

Pull out the detergent drawer. Remove the siphon plug and clean any residual softener thoroughly. Fit the cleaned siphon plug in its location. Check it is fitted properly.

Cleaning the Door Seal and Window

- Wipe the window and seal after each wash to remove lint and stains. If lint builds up, it can cause leaks.
- Remove any coins, buttons and other objects from the door seal after each wash.

Cleaning the Drain Filter

Before cleaning the drain filter, switch off and unplug the washing machine.

1. Carefully loosen the drain filter. Water may drain out - this is normal.
2. Unscrew the filter to remove it.
3. Remove any lint and debris before carefully replacing the filter.
4. Turn the filter clockwise to screw back into place.

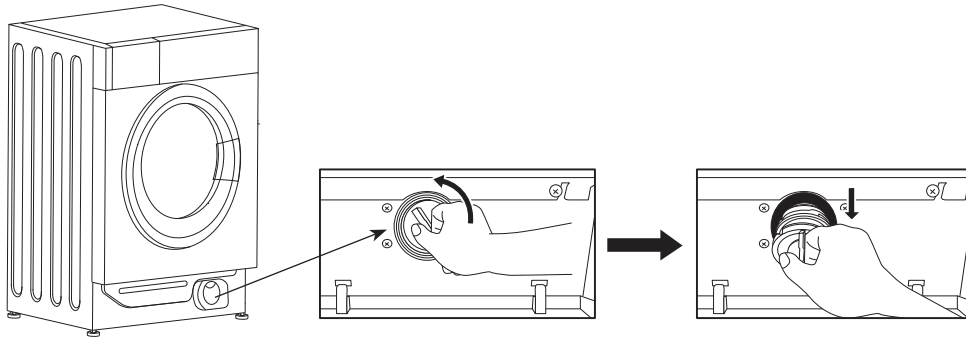

Preventing a Frozen Water Supply Hose

If your washing machine is delivered in freezing weather conditions, leave it at room temperature for 24 hours after you've set it up before using it. This ensures there's no ice blocking the water supply hose. If your water supply hose freezes, add 2 or 3 litres of warm water to the drum. Then run a "Drain" only programme.

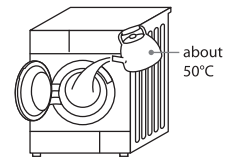

Cleaning the Filter Net of the Water Supply Hose

1. Turn the water supply off at the tap.
2. Close the washing machine door and select "Drain" programme and press the **Start / Pause** button.
3. When finished, turn the power off. Remove the water supply hose from the tap.
4. Manually remove the filter net located on the tap side of the water supply hose and clean using a small brush (e.g. a toothbrush).
5. Return the filter net to its original position.
6. Re-connect the water supply hose to the tap and turn the tap back on, checking for leaks.

Error Codes

Display LED	Description	Solutions
E10	Inlet water problem	<ul style="list-style-type: none"> • Open the water tap, to check if the inlet hose is squashed or kinked. Straighten the inlet hose. • Check if the filter in the inlet valve is blocked or not. Wash the inlet hose. • Check if the water pressure is too low.
E21	Drain problem	<ul style="list-style-type: none"> • Check if the drain pump is blocked. • Wash the drain filter. • Wash and straighten the drain hose.
E30	Door lock problem	<ul style="list-style-type: none"> • Check if the door of the washing machine is closed. • Check if the clothes are pinned by the door.
Others		<ul style="list-style-type: none"> • Please call the service line if there is any other issue.

Specifications

Parameter	
Washing Capacity	7.0kg
Dimension(W*D*H)	595*540*825
Net Weight	63kg
Rated Power	2000W
Power Supply	220-240V~,50Hz
MAX.Current	10A
Standard Water Pressure	0.05MPa~1MPa

Brand:
 Model:GDHA INTWM7KG
 Rated capacity:7kg
 Energy efficiency class:A+++
 EU Ecolabel:N/A

Energy consumption 174kwh per year, based on 220 standard washing cycles for cotton at 60°C/40°C at full and partial load, and the consumption of the low-power modes. Actual energy consumption will depend on how the appliance is used.

Water consumption 10000 litres per year, based on 220 standard washing cycles for cotton 60°C /40°C at full and partial load. Actual water consumption will depend on how the appliance is used.

Spin-drying efficiency class B on a scale from G (least efficient) to A (most efficient)
 Maximum spin speed:1400rpm

Consumption values(1400rpm):

Standard Programme	Load	Energy consumption	Water consumption	Remaining moisture content	Programme duration
Cotton 60°C	7kg	0.82kwh	50L	50%	229min
Cotton 60°C	3.5kg	0.82kwh	42L	55%	209min
Cotton 40°C	3.5kg	0.62kwh	42L	55%	166min

Notes:

1. Programme setting for testing in accordance with applicable standard EN60456-2011.
2. When using the test programmes, wash the specified load using the maximum spin speed.
3. The actual parameters will depend on how the appliance is used, and maybe different with the parameters in above mentioned table.

Off mode power consumption:0.5W
 Left-on mode power consumption:1.0W

Airborne acoustical noise (washing):57
 Airborne acoustical noise (spinning):76

Notes: The airborne acoustical noise emissions during washing/spinning for the cotton 60°C programme at full load.

Customer Care

Please keep this handbook in a safe place as the information inside may be of use should you sell, or pass on the appliance. Please fill in the model number and serial number in the spaces provided below as they will assist us should you need to call.

0844 815 3747

When you dial this number you will hear a recorded message and be given a number of options. This indicates that your call has been accepted and is being held in a queue. Calls are answered in strict rotation as our Customer Care

Model No							
4	4	4					
Serial No							

Representatives become available.

Enter appliance numbers here for future reference:

These numbers can be found on your appliances data badge.
Outside the UK and Northern Ireland, refer to your local supplier.



Stoney Lane, Prescott, Merseyside, L35 2XW

Part Number: xxxx